



PROSTAR™ ELECTRIC CHAIN HOIST

CAPACITIES
113 to 500 kg

SPEEDS
2 to 12 mtr/min

VOLTAGES
Single & 3-phase available

Lightweight, quiet and portable the CM Prostar is designed and built for the unique rigging needs encountered at small venues. Featuring an overload device that protects the hoist, operator and structure from damaging overloads. New swivel hook suspension allows for easy attachment to slings and pick points.

KEY FEATURES

DC ELECTRO-MECHANICAL DOUBLE BRAKES

Non-adjusting for low maintenance and quiet operation.

GEARING

Precision-machined gears are heat treated for strength and durability.

CHAIN GUIDE

One piece chain guide won't jam and allows for smooth operation.

HOUSING

Lightweight and durable cast aluminum with black, powder coat finish for low visibility.

LIFT WHEEL

CM patented 10-pocket, oblique-lay lift wheel for quiet and smooth operation.

LOW VOLTAGE CONTROL

110v for long cable runs without voltage drop. 24v and 48v optional.

DUTY CYCLE

H-4 duty rated, designed for heavy-duty applications.

STANDARD FEATURES

OVERLOAD PROTECTION

Helps prevent lifting of dangerous overloads.

CHAIN STOP

Mounted on load chain to prevent over travel.

METRIC RATED

LOAD CHAIN

Designed and manufactured by Columbus McKinnon. Zinc plated to protect against corrosion. Optional black phosphate finish.

OPTIONAL FEATURES

CHAIN BAG

Easy-to-mount, cloth-type bags.

DOUBLE BRAKE

ENCODER



Swivel Hook
with latch

Swivel Hook with
Latchlok® latch

NOW AVAILABLE WITH OPTIONAL SWIVEL HOOK SUSPENSION

Get the versatility and flexibility you need to rig truss, lighting and audio in confined spaces. Optional swivel hook rotates a full 360° to allow for easy attachment to slings and pick points.



DIMENSIONS

Drawing legend	Reeving	
	Single	Double
A	279mm	308mm
B	75mm	89mm
C	73mm	60mm

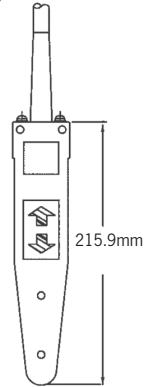
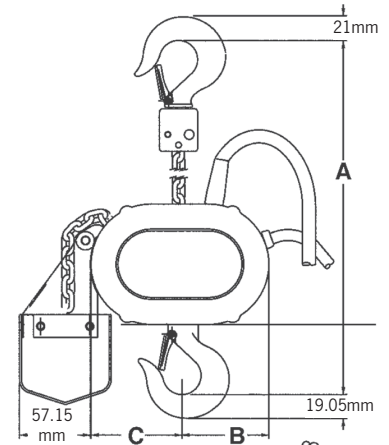
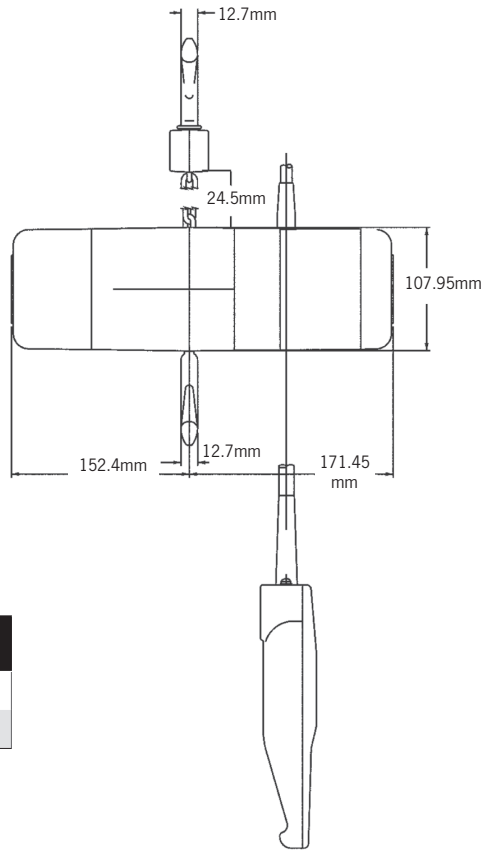

SWIVEL HOOKS (OPTIONAL)

Product Code	Description
10001130K	Prostar Swivel Latch-Type Hook Suspension
10001297K	Prostar Swivel Latchlok Hook Suspension

SPECIFICATIONS PROSTAR

Code	Rate Capacity	Reeves fall of chain	Motor HP	Lift Speed	Hoist weight (unchained)	Chain weight per metre	Full load amps	
							1-phase	3-phase
2041	136kg	1	1/6	3m/min	12.7	0.35kg	3.6	
2043	136kg	1	1/6	4.8m/min	12.7	0.35kg		.6"/1.1"
2191	226kg	1	1/6	3m/min	12.7	0.35kg	3.6	
2189	250kg	1	1/6	4m/min	12.7	0.35kg		.6"/1.1"
2046	272kg	2	1/6	2m/min	16.3	0.7kg		.6"/1.1"

*415 volt operation

*220 volt operation



Rate Capacity	Lift Speed	Operating Voltage		
		Single phase	Three phase	
136kg	4.8m/min	220-1-50/60	220-3-50/60	415-3-50/60
136kg	7.3m/min	-	220-3-50/60	415-3-50/60
136kg	12m/min	-	220-3-50/60	415-3-50/60
226kg	3.7m/min	220-1-50/60	-	-
226kg	4.8m/min	-	220-3-50/60	415-3-50/60
226kg	6m/min	-	220-3-50/60	415-3-50/60
250 kg	4m/min	-	-	415-3-50/60
272kg	2m/min	-	-	415-3-50/60

COLUMBUS MCKINNON CORPORATION ENTERTAINMENT PRODUCTS
 Knutsford Way, Sealand Industrial Estate, Chester CH1 4NZ United Kingdom
 Tel:+44 (0) 1244 375375 · Email: sales.uk@cmco.eu · www.cmco.com